

PHOTO SENSORS

The Companies

How To Use This Catalog

Series Index

Standard Certification/Environment Declaration

Sample Applications

Fiber Optic Sensors

Embedded Amplifier Photo Sensors

Background Suppression Sensors

Color / Mark Sensors

Laser / Harsh Environment

AC/DC Power Supply Photo Sensors

Products for Specific Applications

Accessories

Ultrasonic Sensors

Light Curtain Sensors

Sensors for Steel & Heavy Industries

Power Supply / Sensor Control Units

Model Index

Series Index

Sample Applications

Fiber Optic Sensors

Embedded amplifier photo sensors

Background suppression photo sensors

Color Sensors / Mark Sensors

Laser/Harsh Environment

AC/DC power supply photo sensors

Products for Specific Applications

Accessory

Ultrasonic Sensors

Light Curtain Sensors

Photo Sensors for Steel and Heavy Industries

Power supply units/Sensor control units

Model Index

Sample Applications

Semiconductor

Electronic Component Mounting

Automatic assembly

Consumer electronics/OA

Metal processing

Steel/Ceramic

Delivery/Transportation

Logistics

Automobile

Textile

Rubber/Plastic

Printing

Packaging/Food/Drug

Safety

Sanitary/Amusement

etc.

Semiconductor

1. Color identification of film or resin plates	4
2. Detection of silicon wafers	4
3. Collective detection of glass substrates	4
4. Glass wafer detection	4
5. Silicon wafer detection	4
6. Detection of liquid crystal glass	4
7. Wafer notch detection	5
8. Detection of glass substrate protrusion	5
9. Robot arm-mounted sensor	5
10. Detection of object on IC tester	5
11. Detection of wafers in carrier	5
12. Detection of ICs in transparent sticks	5
13. Detection of wafer in cleaning tank	6
14. Collective detection of wafers	6
15. Detection of pitch holes on IC frame	6
16. Detection of glass substrate for PDP	6
17. Detection of chips on lead frames.....	6
18. Detection of protrusion of wafers	6
19. Detection of LCD board in vacuum tank	7
20. Mapping of hard disk	7
21. Robot hand detection	7
22. Wafer carrier detection	7
23. Wafer position detection	7
24. Detection of wafers in vacuum tank	7
25. Wafer detection	8

Electronic Component Mounting

26. Detection of passage of PCB.....	8
27. Detection of defects in capacitors	8
28. Detection of lifting of tape feeder	8
29. Detection of lead frames.....	8
30. Detection of passing condensers	8
31. Substrate detection	9
32. Checking of presence of silver paste	9
33. Detection of lead frame plating	9
34. Checking for upside-down electronic components.....	9
35. PCB detection	9
36. Detection of objects of identical material	9
37. Counting of minimal parts	10
38. Geometric defect inspection	10
39. Electronic component detection	10
40. Positioning of hybrid snsubstrates	10
41. Positioning of PCBs	10
42. Quantity/position check	10

Automatic assembly

43. Detection of exhausted parts in parts feeder	11
44. Checking for the presence of caps	11
45. Outer diameter inspection	11
46. Weld joint detection	11

Automatic assembly

47. Checking for upside-down parts	11
48. Checking of parts assembly.....	11
49. Position control of stick-on tape	12
50. Checking the shape of coated object.....	12
51. Detection of position of mounter heads	12
52. Detection of level of material inside hopper	12
53. Work detection	12
54. Classifying objects by length	12

Consumer electronics/OA

55. Checking of presence of CD	13
56. FAX arrival notification	13
57. Positioning of fluorescent tubes	13
58. Checking for print	13
59. Checking for upside-down CD-ROMs	13
60. Detection of double feed of CDs	13

Metal processing

61. Detection of crack in bearing bushings	14
62. Detection of passage of coils	14
63. Detection of falling processed works	14
64. Measurement of outer diameter of pipes	14
65. Checking of evenness of steel plates.....	14
66. Detection of loose wire rods	14
67. Detection of Passage of thin objects	15
68. Thin objects detection	15
69. Detection of remaining amount of coiled material ...	15
70. Detection of overflow of press cuttings	15
71. Detection of defective taping of nails	15

Steel/Ceramic

72. Winding control	15
73. Detection of red-hot steel	16
74. Detection of presence of material in the furnace	16
75. Checking for missing tile	16
76. Detection of formed bottles	16
77. Detection of glass plate at outlet of furnace	16

Delivery/Transportation

78. Detection of passage of automobiles	16
79. Detection of height of vehicles	17
80. Detection of a vehicle in a multilevel parking garage.....	17
81. Detection of vehicles for ETC	17
82. Detection of objects in limited range	17
83. Detection of approaching train	17

Logistics

84. Prevention of collision	17
85. Detection of object under strong ambient light	18
86. Checking of arrival of delivery trucks	18

Logistics

87. Distance control	18
88. Transmission of signals to AGV carriages	18
89. Detection of objects falling in inconstant points	18

Automobile

90. Picking sensor	18
91. Detection of breakage of drill bit	19
92. Checking for mixed bearing outer cases	19
93. Detection of parts on conveyor	19
94. Detection of engine head covers	19

Textile

95. Detection of thread dyeing unevenness	19
96. Detection of solid wire among stranded wires (detection of cut)	19
97. Checking for presence of thread in industrial sewing machine	20
98. Broken thread detection	20
99. Bobbin detection	20
100. Fabric seam detection	20

Rubber/Plastic

101. Detection of hole or tear in opaque sheet	20
102. Tire detection	20
103. Long distance tire detection	21
104. Detection of rubber plate	21
105. Transparent tray detection	21
106. Rubber cap detection	21

Printing

107. Sensor for counting number of rotations	21
108. Positioning of rolled paper	21
109. Detection of lifting of ejected paper	22
110. Detection of tapes on paper joint lines	22
111. Control of roll thickness	22
112. Control of meandering of transparent films	22
113. Detection of absorption in lettuce wrapping machine	22
114. Detection of broken paper on rotary press	22

Packaging/Food/Drug

115. Level control	23
116. Mark detection	23
117. Detection of lifting of caps	23
118. Bottle cap packing detection	23
119. Control of film rolling	23
120. Distinction of overlap sheets	23
121. Detection of teabag strings	24
122. Detection of shampoo bottles	24

Packaging/Food/Drug

123. Detection of rice balls for sushi	24
124. Detection of steamed fish paste on belt conveyor	24
125. Detection of level of liquid in pipe	24
126. Detection in chemical atmosphere	24
127. Egg package detection	25
128. Detection of slipped labels	25
129. Content checking	25
130. Identification of height of medicines	25
131. Detection of register marks	25
132. Detection of level of liquid in tank	25
133. Transparent film detection	26
134. Transparent PET bottle detection	26
135. Detection of register mark on wrapping paper for Japanese sweets	26
136. Label detection	26

Safety

137. Safety sensor for overhead hazard protection	26
138. Detection of ignition	26
139. Detection of entering objects into machine	27

Sanitary/Amusement

140. Starting switch for game machine	27
141. Sensor for automatic faucet	27
142. Sensor for automatic flushing	27
143. Sensor for stopping carts	27
144. Sensor for activating game machine	27
145. Sensor for hot air drying	28

etc.

146. Detection of objects in harsh environment	28
147. Detection of film in dark room	28
148. Drum rotation control	28
149. Detection of still cars in parking lot	28
150. Divergence control	28
151. Detection of person at entrance	29
152. Detection of labels in place	29
153. Detection of remaining person	29
154. Control of height of industrial radio-controlled helicopter.	29
155. Guest counting	29
156. Detection of coated plywood board	29

Sample Applications

Semiconductor

1 Color identification of film or resin plates

Identifying the color of film plates or resin plates with color proportion and brightness.

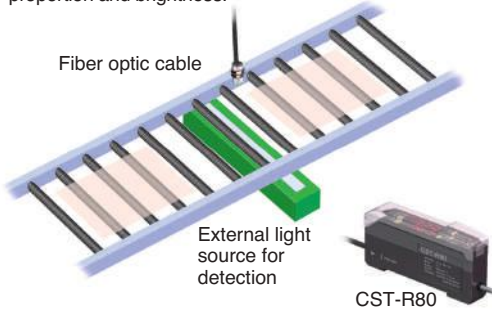

Passive color matching sensor **CST-R80** See **P.284**

2 Detection of silicon wafers

Securely detecting silicon wafers even when water drops are on their surface.

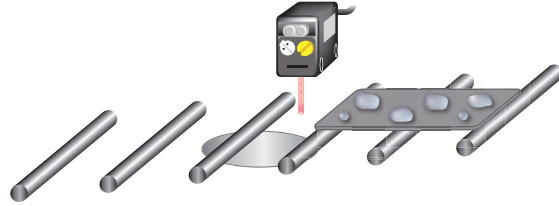

Embedded amplifier photo sensor **DN-S10R** See **P.236**

3 Collective detection of glass substrates

Detection of glass substrates in cassette.

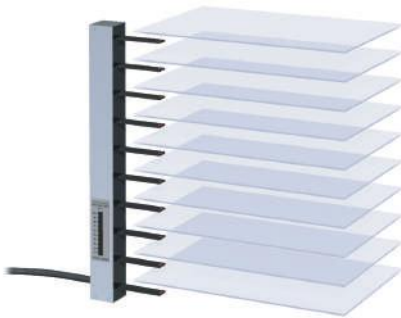

Glass substrate sensor **ASW Series** See **P.356**

4 Glass wafer detection

Ultrasonic sensor reliably detects wafers with water drops on them.

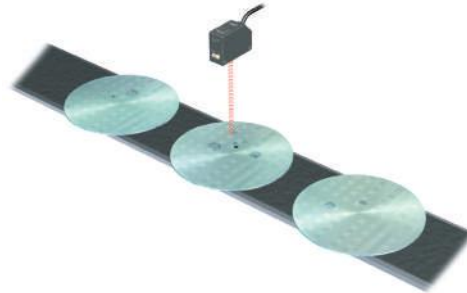

Ultrasonic sensor **US-R25** See **P.428**

5 Silicon wafer detection

Compact ultrasonic sensor used for "underneath" detection.

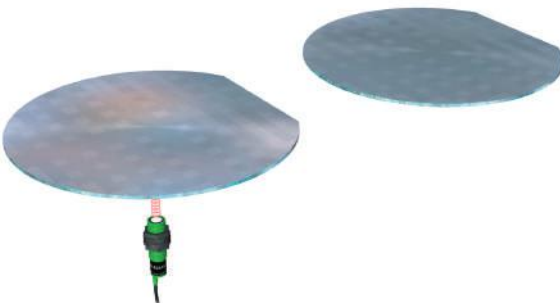

Ultrasonic sensor **US-S25AN** See **P.424**

6 Detection of liquid crystal glass

Mapping liquid crystal glass. A large PCB with a wide curve can be detected securely.

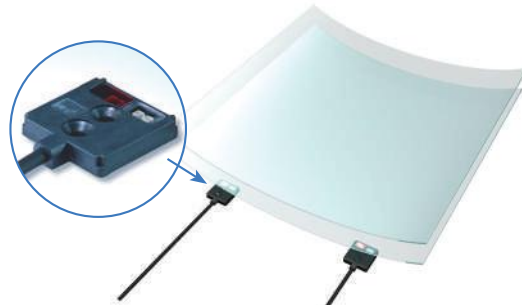

Embedded amplifier photo sensor **ASG series** See **P.350**

Sample Applications

Semiconductor

7

Wafer notch detection

Coaxial reflective type fiber cable with lens unit detecting small spot for notch detection.

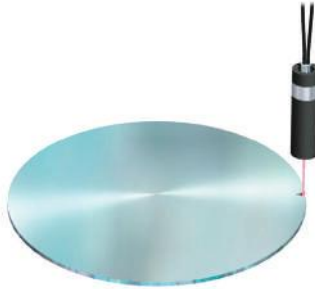

Fiber optic sensor **FX84BC FA200**

See **P.119**

8

Detection of glass substrate protrusion

Narrow view fiber optic cable detecting substrate protrusion from cassette.



Fiber optic sensor **FTN5BC**

See **P.83**

9

Robot arm mounted sensor

Convergent reflective fiber optic cable embedded in arm.



Fiber optic sensor **FZV8301BC**

See **P.124**

10

Detection of object on IC tester

Passage of flat ICs checked.



Fiber optic sensor **F2R FT8BC**

See **P.77**

11

Detection of wafers in carrier

Wafer edges detected.



Fiber optic sensor **F2R FR7BC**

See **P.104**

12

Detection of ICs in transparent sticks

Ultra-thin sensor fitting in space between sticks.

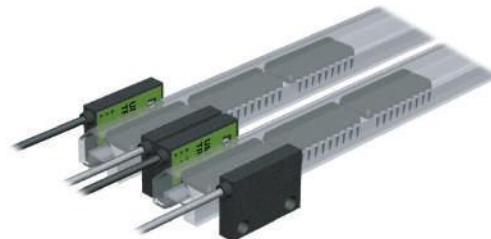

Embedded amplifier photo sensor **UM2 Series**

See **P.182**

Sample Applications

Semiconductor

13 Detection of wafer in cleaning tank

PFA sensor installed inside tank.

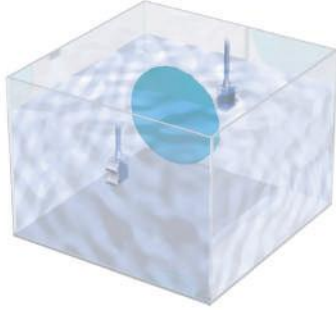

Embedded amplifier photo sensor **PF-T3DS** See **P.314**

14 Collective detection of wafers

Presence of wafers in cassette collectively checked for mapping.

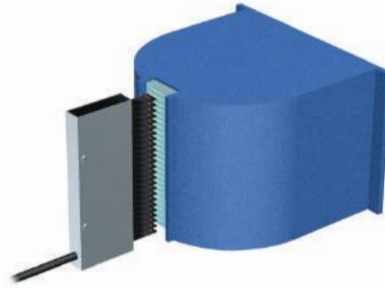

Wafer sensor **ASW-SG Series** See **P.352**

15 Detection of pitch holes on IC frame

Detecting even a small pitch hole when combined with a lens unit.

Fiber optic sensor

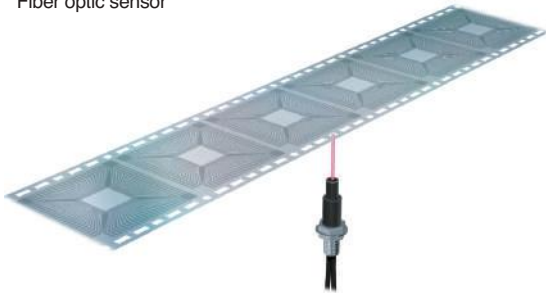

Fiber optic sensor **F70AR FZV8202BC** See **P.125**

16 Detection of glass substrate for PDP

Glass substrates detected in vacuum chamber.



Vacuum fiber optic cable **GXHN710V** See **P.134**

17 Detection of chips on lead frames

Variable focus reflective laser sensor checking presence of chips.



Laser sensor **LD-S20R** See **P.304**

18 Detection of protrusion of wafers

Protrusion of wafer detection.

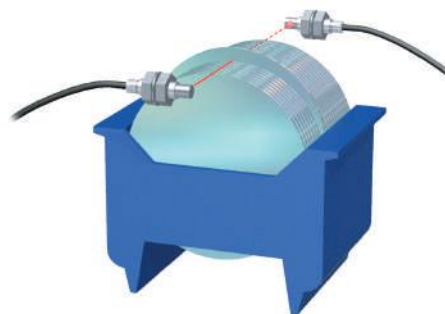

Fiber optic sensor **FTV7BC** See **P.81**

Sample Applications

Semiconductor

19 Detection of LCD board in vacuum tank

Detection with general purpose fiber optic cable of regular reflection through view port.

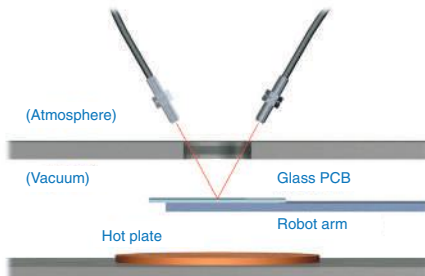

Fiber optic sensor **FT105BC**

See **P.76**

20 Mapping of hard disk

A small pitch type of liquid crystal PCB sensor.
Glass PCB sensor.



Glass substrate sensor **ASW Series**

See **P.356**

21 Robot hand detection

Detection of Robot hand with glass substrate on it in order to stopping XY stage movement.

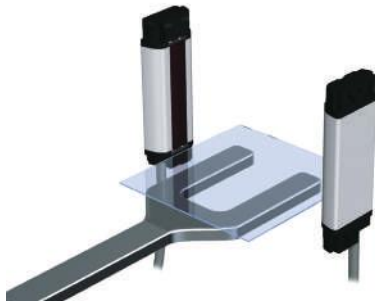

Light curtain **SSC-T800 Series**

See **P.460**

22 Wafer carrier detection

Wafer carrier detected through view port of vacuum tank.

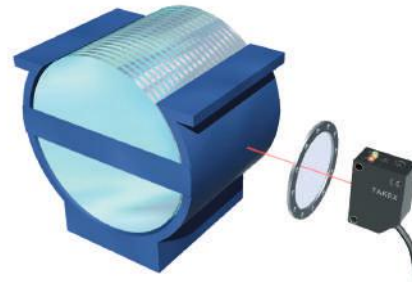

Background suppression photo sensor **DL-S10R**

See **P.254**

23 Wafer position detection

Narrow view fiber optic cable allowing high accuracy detection.

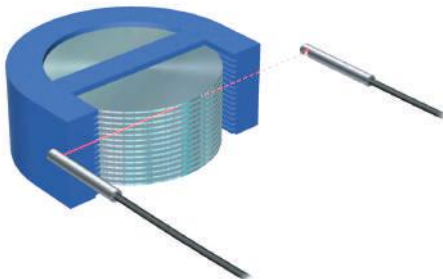

Fiber optic sensor **FTVN5BC**

See **P.84**

24 Detection of wafers in vacuum tank

Heat-resistant vacuum fiber optic cable with V-shaped design.
Convergent reflection is not affected by the background.

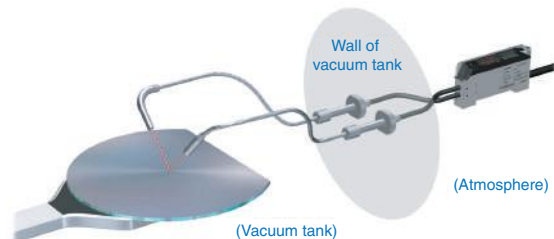

Vacuum fiber optic cable **GTSH/GTH Series**

See **P.134**

Sample Applications

Semiconductor • Electronic Component Mounting

25

Wafer detection

Heat resistant proof vacuum through beam fiber optic cable detecting wafer in a vacuum tank.



Fiber optic sensor **GTHN700V Series**

See **P.135**

26

Detection of passing PCB

The sensor built in the machine detects passing PCBs. You can install it anywhere you like. Embedded amplifier photo sensor.

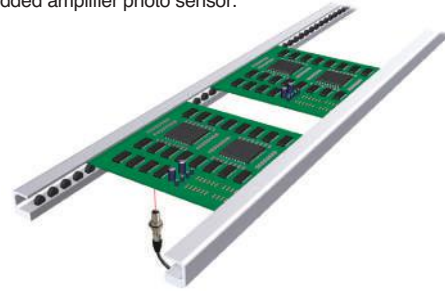

Embedded amplifier photo sensor **UX Series**

See **P.178**

27

Detection of defects in capacitors

Bends above taping detected with through beam fiber optic cable.



Fiber optic sensor **F2R FT5BC**

See **P.78**

28

Detection of lifting in tape feeder

Lifting in tape feeders in line can be detected by spot laser beam.

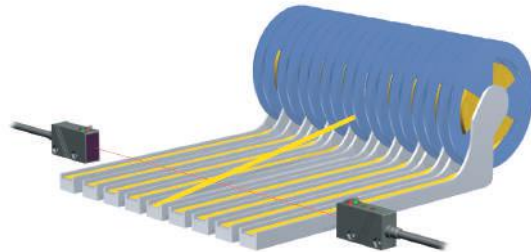

Laser sensor **LD-T20R**

See **P.304**

29

Detection of lead frames

Detecting lead frames from their bottoms, with a thin head of 2mm. Fiber optic sensor.

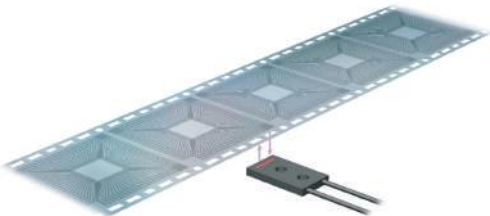

Fiber optic sensor **F70AR FZV8202BC**

See **P.125**

30

Detection of passing condensers

The sensor built in the guide detects condensers. Embedded amplifier photo sensor.

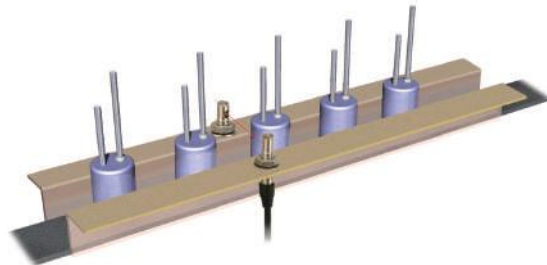

Embedded amplifier photo sensor **UX-T50DS**

See **P.178**

Sample Applications

Electronic Component Mounting

31

Substrate detection

Substrates detected in insertion machine by convergent reflective method, unaffected by board color or background.

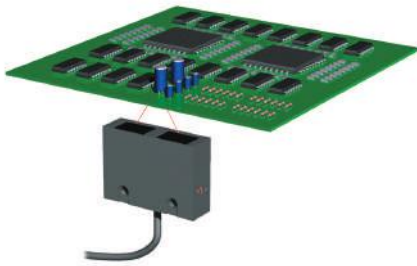

Embedded amplifier photo sensor **DLZ-S30** See **P.368**

32

Checking of presence of silver paste

Even a small amount of paste can be detected with a spot size of 0.5 mm in diameter.

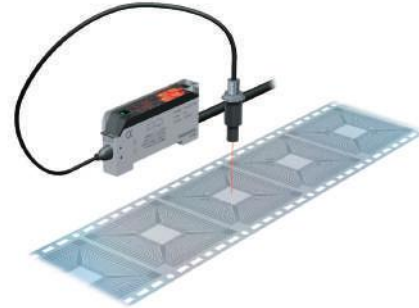

Fiber optic sensor **F70AR FX210J FA240** See **P.120**

33

Detection of lead frame plating

Reliable detection achieved by determination of RGB color component and brightness.

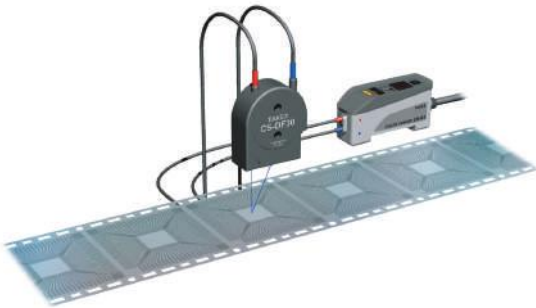

Color sensor **CS-D3 CS-DF30** See **P.274**

34

Checking for upside-down electronic components

Blue light fiber optic sensor used for checking whether the right sides of electronic components are facing up in part chute.



Fiber optic sensor **F70AB FRS83BC** See **P.110**

35

PCB detection

Ultra thin sensor allowing to conserve installation space.

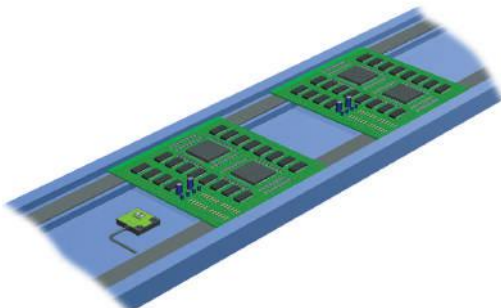

Embedded amplifier photo sensor **UM-R5T** See **P.196**

36

Detection of objects of identical material

When an object is made of the same material with the background, the sensor senses tiny change of light intensity and detects it with pulse fiber amplifiers.



Fiber optic sensor **F10R-AT** See **P.58**

Sample Applications

Electronic Component Mounting

37 Counting of minimal parts

Wide area fiber optic cable allowing wide-view detection.

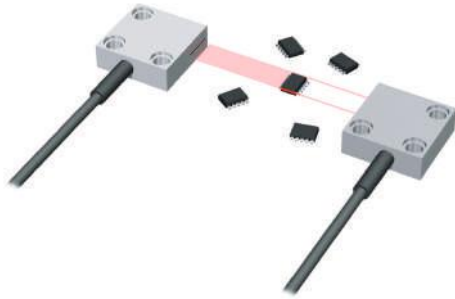

Fiber optic sensor **FTLV702BC** See **P.95**

38 Geometric defect inspection

Missing parts on substrates, etc. detected.

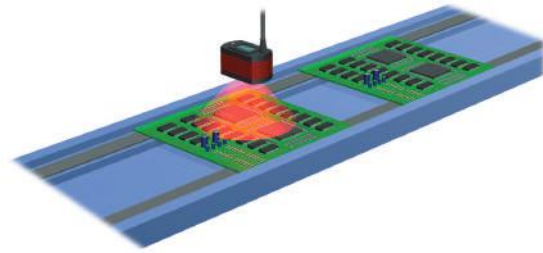

BGS photo diode array sensor **VS Series** See **P.362**

39 Electronic component detection

Molded parts detected with background suppression photo sensor unaffected by color variation.

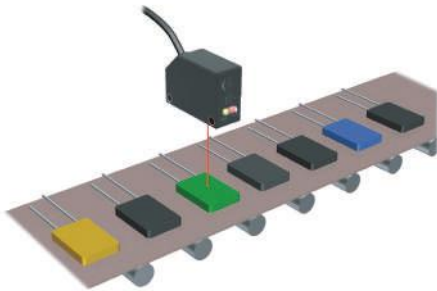

Background suppression photo sensor **DL-S10R** See **P.254**

40 Positioning of hybrid substrates

High precision positioning achieved with micro-spot laser beam.

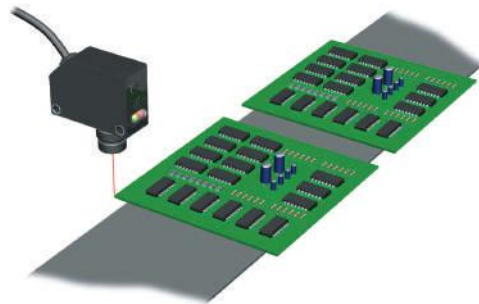

Laser sensor **LD-S20R** See **P.304**

41 Positioning of PCBs

Stop position of PCBs determined with U-shaped through beam photo sensors that are unaffected by color, gloss and warp of PCBs.

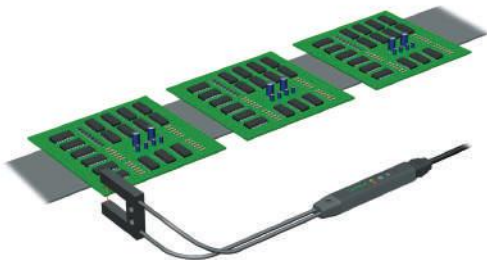

Fiber optic sensor **F2R FU712BC** See **P.90**

42 Quantity/position check

Quantity and position of object in view checked.

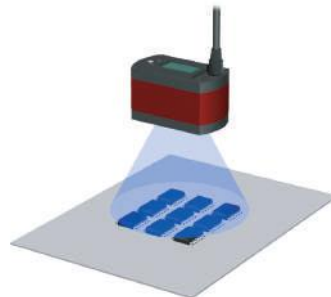

BGS photo diode array sensor **VS Series** See **P.362**

Sample Applications

Automatic assembly

43 Detection of exhausted parts in parts feeder

Parts assumed to have run out when a certain level of light continuously detected for a certain period of time by retroreflective sensor.

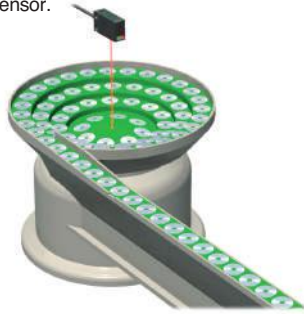

Embedded amplifier photo sensor **GSZ5RS** See **P.208**

44 Checking for the presence of caps

Presence of caps on works checked by retroreflective fiber optic cable.

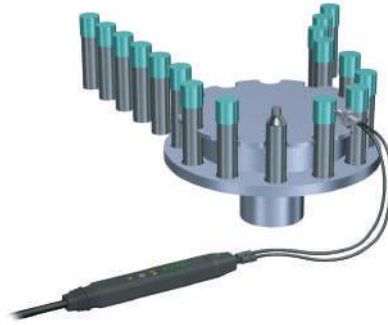

Fiber optic sensor **F2R FR8EBC** See **P.102**

45 Outer diameter inspection

Wide area fiber optic cable used in combination with two-output amplifier for diameter inspection.



Fiber optic sensor **F70TR FTVW7YBC** See **P.96**

46 Weld joint detection

Joint of motor body detected before welding. Variable focus reflective laser sensor allowing optimized adjustment according to distance.

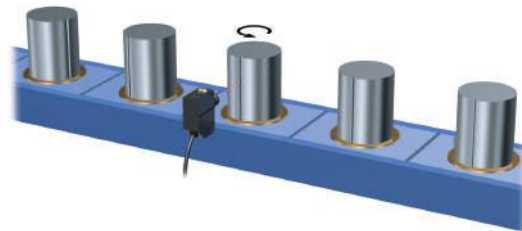

Laser sensor **LD-S20R** See **P.304**

47 Checking for upside-down parts

The side of parts facing up determined by level of reflected light.



Fiber optic sensor **F70AR FX84BC** See **P.119**

48 Checking of parts assembly

The convergent reflective sensor detects objects to be assembled into small parts.

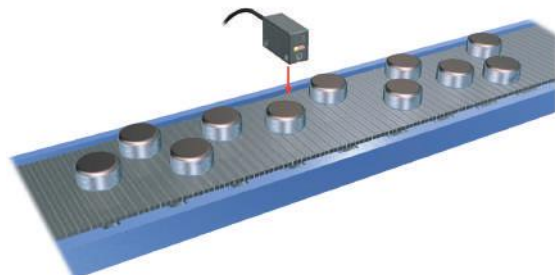

Distance sensor **DL-S Series** See **P.254**

Sample Applications

Automatic assembly

49 Position control of stick-on tape

Analog output fiber optic sensor used for detecting edge of tape for prevention of displacement of tape.

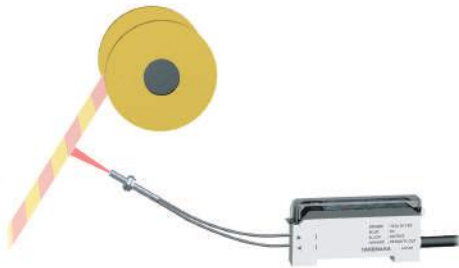

Fiber optic sensor **F71RAN FX801BC** See **P.118**

50 Checking the shape of coated object

Height of coated object determined by separate outputs for light axes.

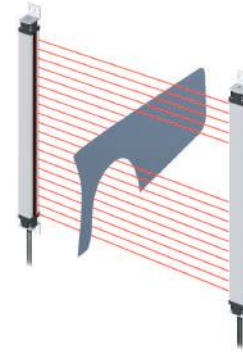

Light curtain sensor **SS-CH Series** See **P.518**

51 Detection of position of mouter heads

The sensor for positioning mouter heads. Ultra-thin and good for space saving.



Embedded amplifier photo sensor **UM-T15DT** See **P.196**

52 Detection of level of material inside hopper

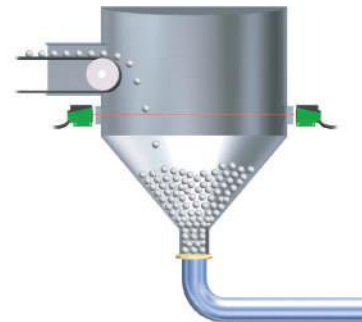

AC/DC power supply photo sensor **NA Series** See **P.336**

53 Work detection

Work detected on parts feeder chute.

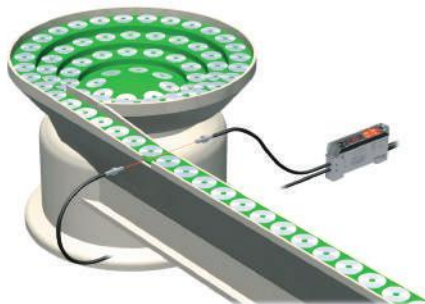

Fiber optic sensor **F70AR FT5BC** See **P.78**

54 Classifying objects by length

Several sensors are used to identify the length of carton boxes.

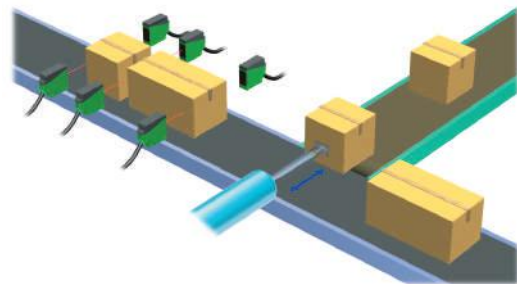

AC/DC power supply photo sensor **NA Series** See **P.336**

Sample Applications

Consumer electronics/OA

55

Checking of presence of CD

Reliable detection achieved without being affected by patterns printed on CD.



Background suppression photo sensor **DL-S Series** See **P.254**

56

FAX arrival notification

FAX arrival detected at delivery point and then reported.

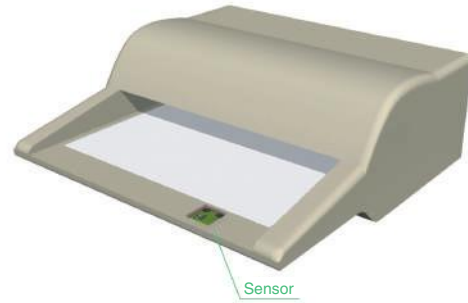

Embedded amplifier photo sensor **UM-R3T** See **P.196**

57

Positioning of fluorescent tubes

Detection of electrodes for the purpose of positioning and marking on fluorescent tubes.

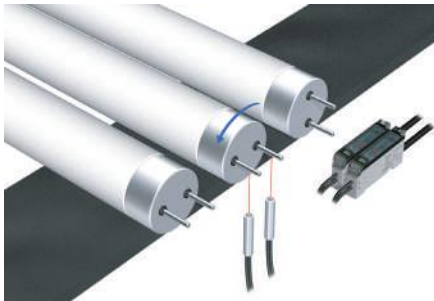

Fiber optic sensor **F71R FR1083BC** See **P.101**

58

Checking for print

Paper rolls checked for missing print.

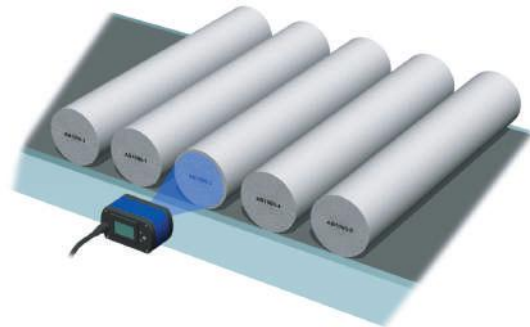

BGS photo diode array sensor **VS-S20B** See **P.362**

59

Checking for upside-down CD-ROMs

High resolution of F70R allows distinction of the two sides of CD.



Fiber optic sensor **F70R FR8EBC** See **P.102**

60

Detection of double feed of CDs

Detected from the side with small spot beam.

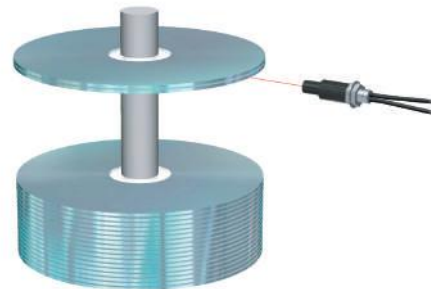

Fiber optic sensor **FX84BC FA240** See **P.119**

Sample Applications

Metal processing

61 Detection of crack in bearing bushings

Surface cracks detected by taking advantage of irregular light reflection on cracks.

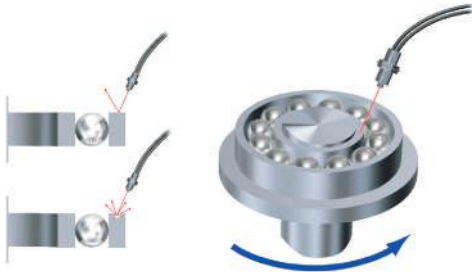

Fiber optic sensor **F70R FX716BC**

See **P.121**

62 Detection of passage of coils

Sequential Array Scanning wide area sensor capable of detecting coils, which do not have enough mass to block light.

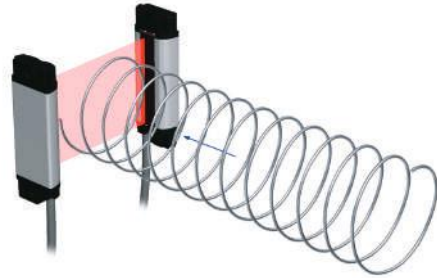

Light curtain sensor **SSC-T800 Series**

See **P.460**

63 Detection of falling processed works

Objects with irregular forms falling at arbitrary points and then detected with Sequential Array Scanning wide area sensor.

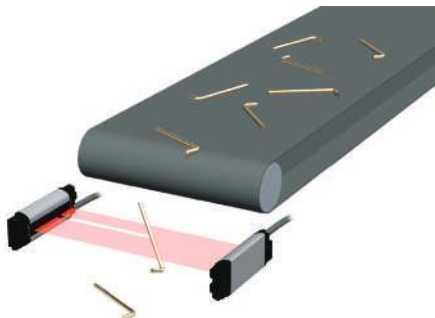

Light curtain sensor **SSC-T800 Series**

See **P.460**

64 Measurement of outer diameter of pipes

Light curtain with separate outputs for each optical axis is used for the purpose of measuring outer diameter of sorting pipes.



Light curtain sensor **SS-CH Series**

See **P.518**

65 Checking of evenness of steel plates

Measurements taken at four corners of steel plate to determine evenness.

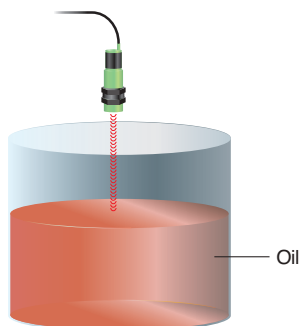

Ultrasonic sensor **US-S25AN**

See **P.424**

66 Detection of loose wire rods

Wire hanging from loose wire rod carried by hook conveyor is detected (sensor used in combination with pinhole plates).

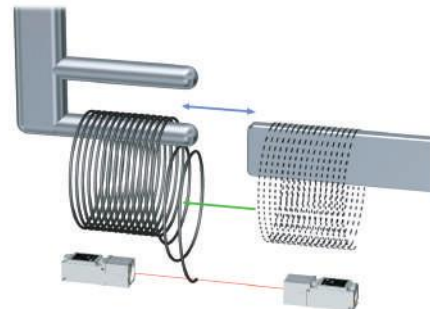

Embedded amplifier photo sensor **NT30F-30P3**

See **P.320**

Sample Applications

Metal processing • Steel/Ceramic

67 Detection of passage of thin objects

Thin objects are detected by Sequential Array Scanning method.

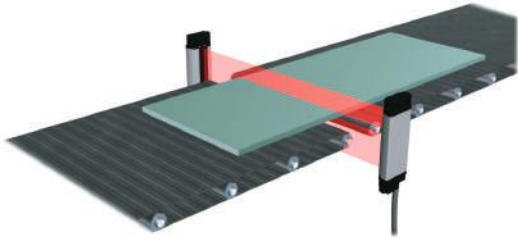

Light curtain sensor **SSC-T800 Series** See **P.460**

68 Thin objects detection

Plate-shaped work passing in arbitrary area is detected with Sequential Array Scanning wide area sensor. Detection is unaffected by plate width.

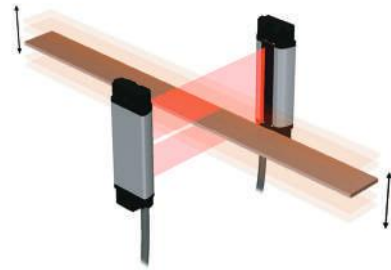

Light curtain sensor **SSC-T800 Series** See **P.460**

69 Detection of remaining amount of coiled material

Remaining amount of coiled material is checked to prevent operation without material and also for material joining.

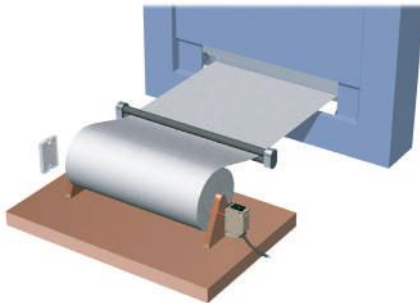

AC/DC power supply photo sensor **NE-M5RD** See **P.332**

70 Detection of overflow of press cuttings

Press cuttings detected as they fill the container. Note: Separate SUS protective covers are available.

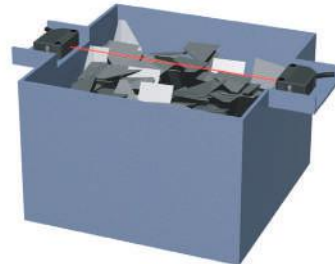

Embedded amplifier photo sensor **GT5RSN** See **P.208**

71 Detection of defective taping of nails

Through beam fiber optic sensor used for detecting nails displaced in taping.

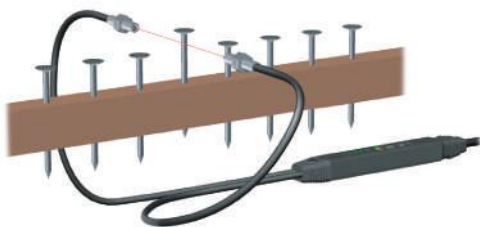

Fiber optic sensor **F2R FT5BC** See **P.78**

72 Winding control

Control of large winder. Long detection distance allows for safe detection of large rolls.

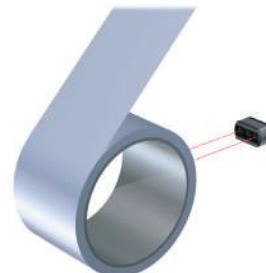

Background suppression photo sensor **DX-7AH** See **P.394**

Sample Applications

Steel/Ceramic • Delivery/Transportation

73 Detection of red-hot steel

Detecting the presence of material at the outlet of furnace. The detecting head is highly heat-resistant.

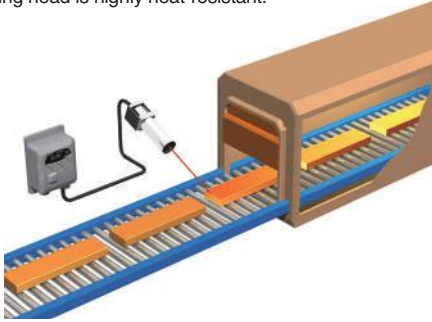

Fiber type **HMD FD-A320**

See **P.532**

74 Detection of presence of material in the furnace.

Detection of presence of material in the furnace. The detecting head is highly heat-resistant.

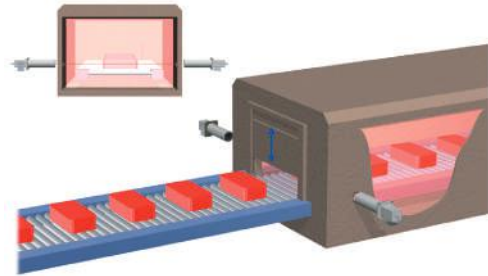

Fiber type **CMD FT44A**

See **P.574**

75 Checking for missing tile

Pallet checked for any missing tile. Reliable detection is achieved without being affected by tile color variation.

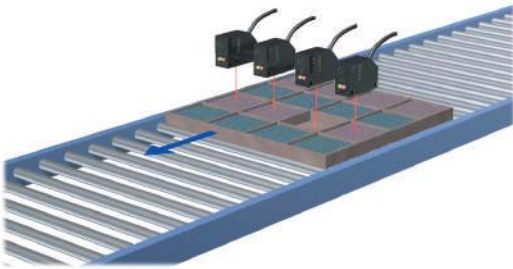

Background suppression photo sensor **DL-S Series** See **P.254**

76 Detection of formed bottles

HMD used for the detection of hot formed bottles.

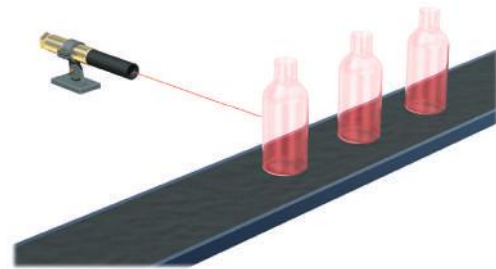

Fiber type **HMD FD-A310C**

See **P.560**

77 Detection of glass plate at outlet of furnace

Heat resistant through beam fiber optic cable with lens unit attached to accomplish long distance detection.

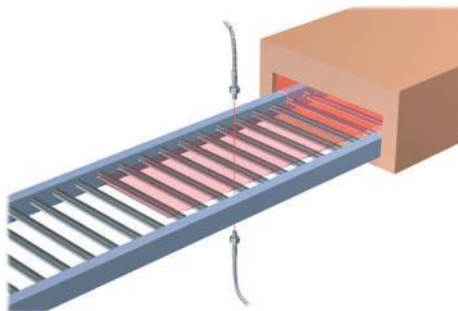

Heat-resistant fiber optic sensor **GTH500J FA514** See **P.99**

78 Detection of passing automobiles

The polarized retroreflective sensor securely detects even glossy objects. The stability indicator displays detecting conditions clearly.



AC/DC power supply photo sensor **NAL-M10RP** See **P.328**

Sample Applications

Delivery/Transportation • Logistics

79

Detection of height of vehicles

High-powered sensor for detecting distances of up to 30 m and alarming excessive height.



AC/DC power supply photo sensor **NA-T30** See **P.336**

80

Detection of a vehicle in a multilevel parking garage.

Detecting the protrusion of a vehicle in a multilevel parking garage hanger.

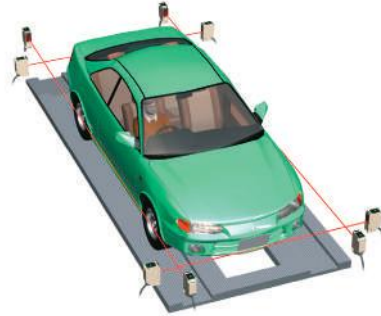

AC/DC power supply photo sensor **NE-T10RD** See **P.332**

81

Detection of vehicles for ETC

Detection via a through beam light curtain with excellent resistance to outside light and environment.

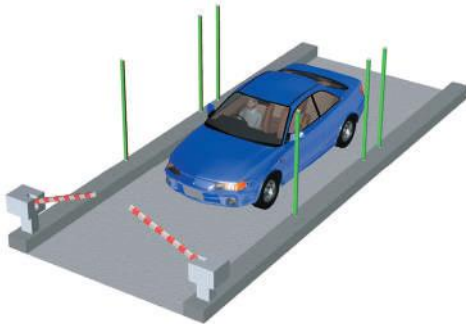

Outside-use light curtain sensor **LST Series** See **P.524**

82

Detection of objects in limited range

Detecting range can be limited by means of zone teaching. Objects passing/moving in front of sensor may be canceled.

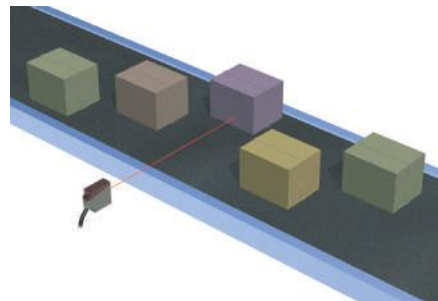

Background suppression photo sensor **DA-S100RP** See **P.246**

83

Detection of approaching train

Detecting a train approaching the station and activating an alert announcement and video monitors.

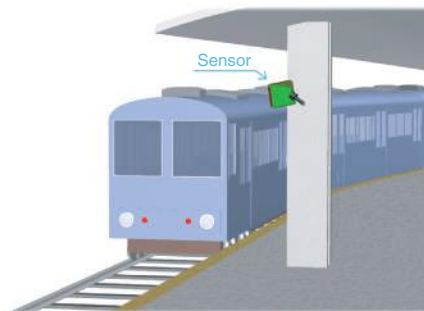

Background suppression photo sensor **DL Series** See **P.266**

84

Prevention of collision

Crain bodies directly detected without reflector to prevent the collision of overhead traveling crains and unmanned crains.



Background suppression photo sensor **DX-7AH** See **P.394**

Sample Applications

Logistics · Automobile

85 Detection of object under strong ambient light

Detection unaffected by bright inverter fluorescent light on inspection lines, etc.

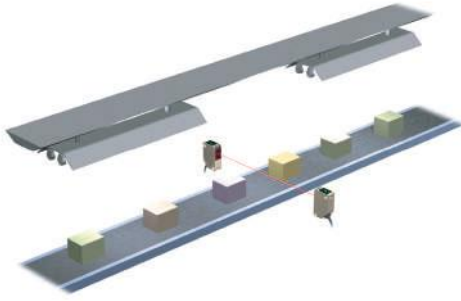

Inverter-protection photo sensor **NEF Series** See **P.224**

86 Checking of arrival of delivery trucks

Arrival of trucks at yard detected.



Background suppression photo sensor **DA-S200P** See **P.246**

87 Distance control

Used for deceleration and stopping control of high-speed unmanned carriages, etc. Analog output used for controlling distance from carriage ahead according to speed. Carriage bodies directly detected without reflector

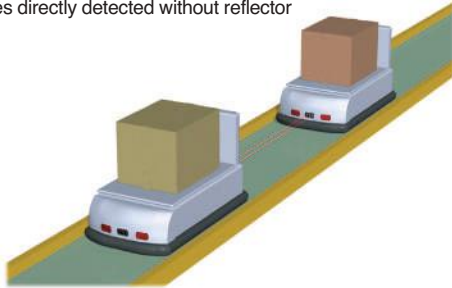

Background suppression photo sensor **DX-7AH** See **P.394**

88 Transmission of signals to AGV carriages

Measuring the distance to the detecting object in the phase differential method and securely detecting a wide area without being affected by the background of the detecting object, glossy surface or color depth.

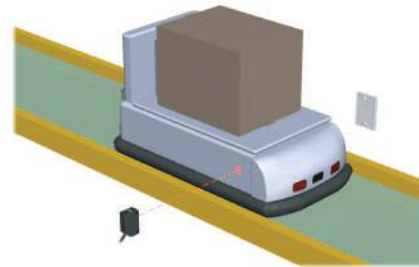

Amplifier built-in photo sensor **GN-M2CR** See **P.188**

89 Detection of objects falling in inconstant points

Detecting irregular shaped objects falling in inconstant points.

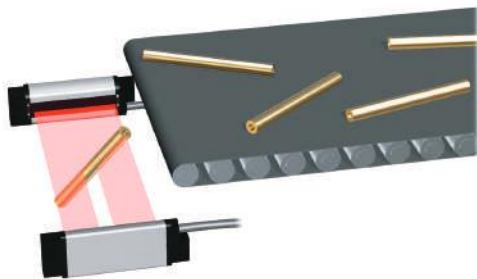

Light curtain sensor **SSC-T800 Series** See **P.460**

90 Picking sensor

A picking sensor for verifying and showing that parts have been taken out. Provided with a large job-light allowing high visibility with a rigid thin metal body of 13mm.

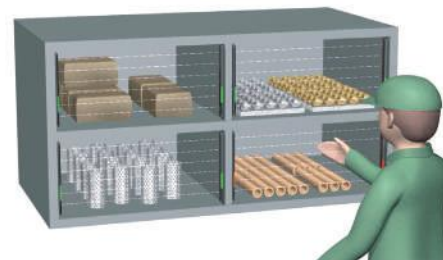

Picking sensor **SSP-T200 Series** See **P.498**

Sample Applications

Automobile · Textile

91

Detection of breakage of drill bit

Drill bit checked for breakage at each stroke. U-shaped sensor of IP 67 requires zero light axis adjustment and provides reliable detection.

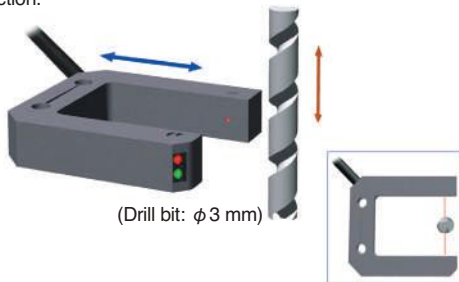

Embedded amplifier photo sensor **AS-U25** See **P.230**

92

Checking for mixed bearing outer cases

Outer bearing cases checked by color marking for the purpose of mixing different models.

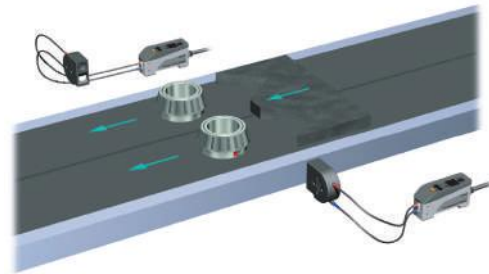

Color sensor **CS-D3 CS-DF10** See **P.274**

93

Detection of parts on conveyor

Highly chemical-resistant PFA sensor used for detecting parts in anticorrosive spraying process.

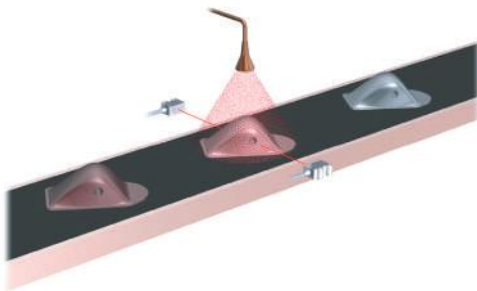

Embedded amplifier photo sensor **PF-T3DS** See **P.314**

94

Detection of engine head covers

Light curtains provide reliable detection of objects in different shapes otherwise unachievable with a single-axis sensor.

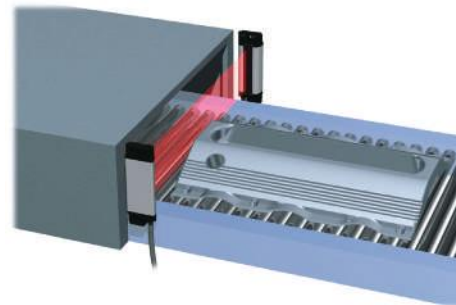

Light curtain sensor **SSC-T800 Series** See **P.460**

95

Detection of thread dyeing unevenness

Inconsistent dyeing detected in the dyeing process. High resolution of F70R for arbitrary setting.

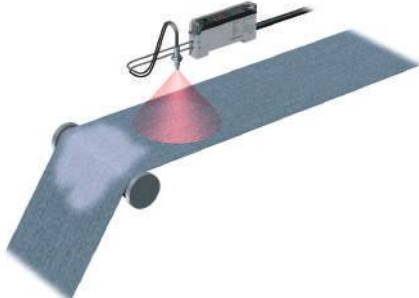

Fiber optic sensor **F70R FX84BC** See **P.119**

96

Detection of solid wire among stranded wires (detection of cut)

Detecting a cut solid wire with a fine laser beam.

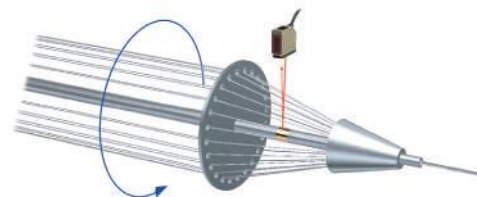

Laser sensor **LD-S33R** See **P.304**

Sample Applications

Textile · Rubber/Plastic

97 Checking for presence of thread in industrial sewing machine

Reflective tape on bobbin shaft is detected therefore providing notification of thread running out.

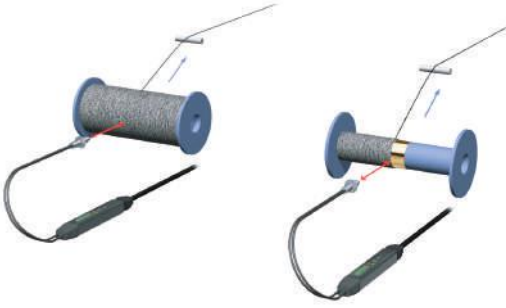

Fiber optic sensor **F2R FX84BC**

See **P.119**

98 Broken thread detection

Loss of reflection of light caused by fluctuation or presence of detected thread with a wide-view sensor, therefore, assumes broken thread.



Embedded amplifier photo sensor **GS5N**

See **P.202**

99 Bobbin detection

Background suppression photo sensor provides reliable detection and is unaffected by variation of bobbin color or shape.

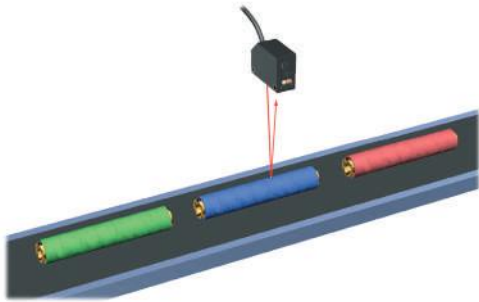

Background suppression photo sensor **DL-S10R**

See **P.254**

100 Fabric seam detection

Seam of adjacent cloths detected in dyeing process.



Fiber optic sensor **F70R FT5BC**

See **P.78**

101 Detection of hole or tear in opaque sheet

Wide area sensor equipped with one-axis output and all-axis output modes provides the detection of a hole or tear by activating the output when light is received in one or more axis.

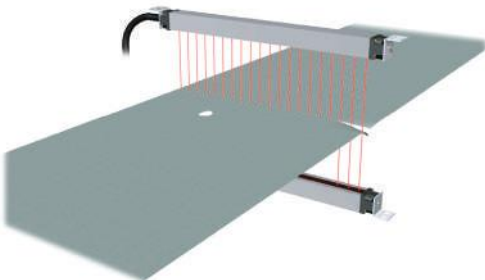

Light curtain sensor **SS10/20/40**

See **P.468**

102 Tire detection

Ultrasonic sensor used for detection regardless of tire size or conveyor color.

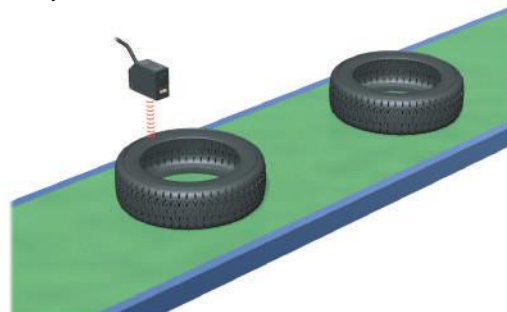

Ultrasonic sensor **US-R25**

See **P.428**

Sample Applications

Rubber/Plastic · Printing

103

Long distance tire detection

Long distance sensor used for extra detecting distance, provides detection of tires in different sizes.

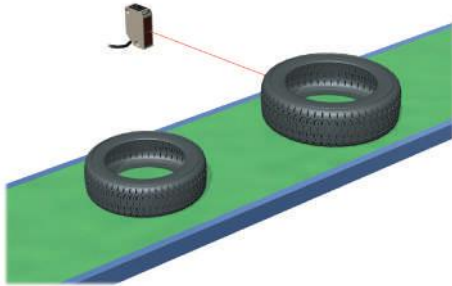

Background suppression photo sensor **DL-S202** See **P.260**

104

Detection of rubber plate

Detecting passage or presence of rubber plates in the cutting process.

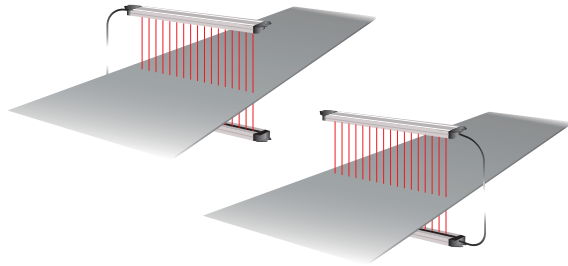

Light curtain sensor **SSU20** See **P.438**

105

Transparent tray detection

Passage of transparent tray detected with ultrasonic sensor.

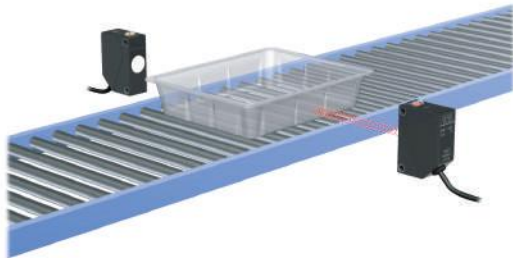

Ultrasonic sensor **US-T50** See **P.428**

106

Rubber cap detection

Diffuse reflective laser sensor used for checking presence of black rubber cap on tip of metal rods. Variable focus function provides optimal focusing of light spot according to distance.

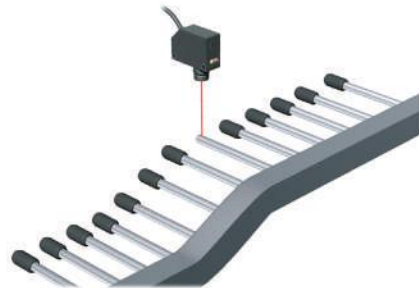

Laser sensor **LD-S20R** See **P.304**

107

Sensor for counting number of rotations

Holes in rotating disk detected for counting number of rotations or measuring speed (RPM).

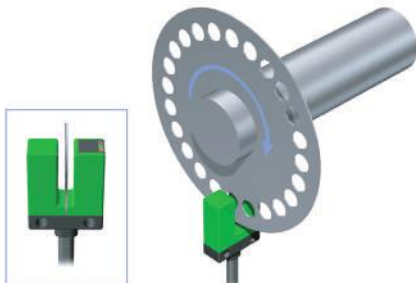

Embedded amplifier photo sensor **PU5** See **P.230**

108

Positioning of rolled paper

Rolled paper positioned on printer. Sensor with focused laser beam ensures high accuracy.

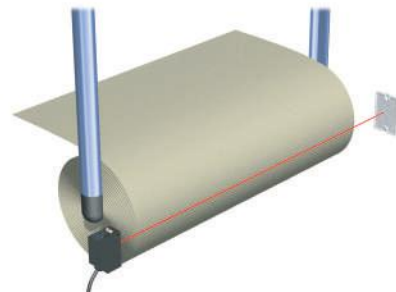

Laser sensor **LD-M10R** See **P.304**

Sample Applications

Printing

109 Detection of lifting of ejected paper

Background suppression photo sensor is unaffected by color variation and therefore used for detecting any lifting of ejected paper.

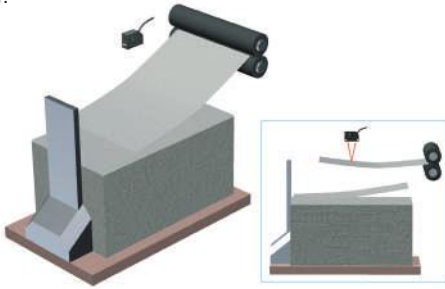

Background suppression photo sensor **DL-S Series** See **P.254**

110 Detection of tapes on paper joint lines

Tapes applied on paper joint lines are detected. Only variations in the light intensity are detected. Gradual changes in light level are ignored.

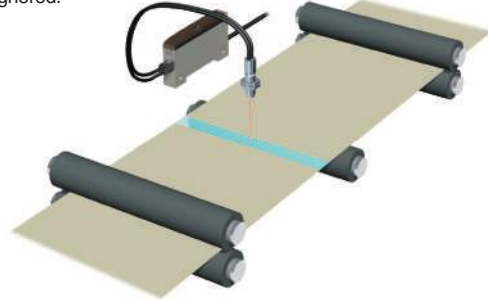

Fiber optic sensor **F10R-AT FR105BC** See **P.100**

111 Control of roll thickness

Good for dust proofing in a dusty workshop.

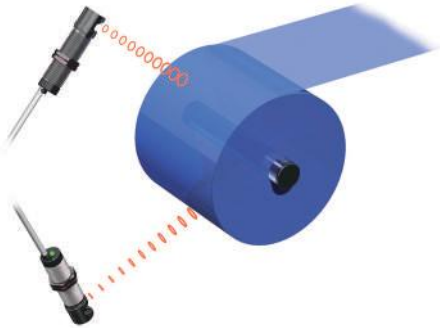

Ultrasonic analogue sensor **USA-S1AN** See **P.416**

112 Control of meandering of transparent films

An ultrasonic sensor can control meandering of transparent films without being affected by printing patterns, which is difficult for an optical sensor.



Fiber optic sensor **F2R FTV74BC** See **P.80**

113 Detection of absorption in lettuce wrapping machine

The limited range reflective sensor detects lettuce wrapping without being affected by color or shape of the detecting object.

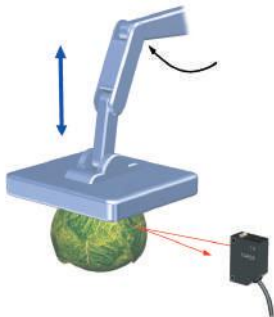

Background suppression photo sensor **DL-S Series** See **P.254**

114 Detection of broken paper on rotary press

Convergent reflective sensor not affected by print colors.



Background suppression photo sensor **DN-S Series** See **P.236**

Sample Applications

Packaging/Food/Drug

115

Level control

Grain or fine particles in tank are detected. Stable detection is ensured even with materials absorbing ultrasonic wave.



Background suppression photo sensor **DX-7AH** See **P.394**

116

Mark detection

U-shaped sensor provide easy installation. Register marks on paper are detected by adjusting power of emitted light.

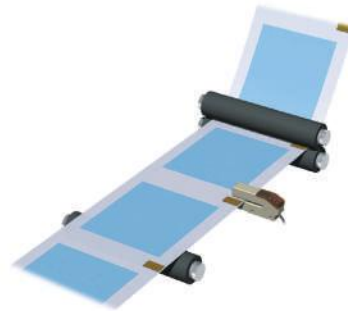

Mark sensor **MC-U2R** See **P.294**

117

Detection of lifting of caps

Lifting of caps due to inadequate tightening, etc. detected with narrow-view fiber optic sensor therefore achieving high accuracy.

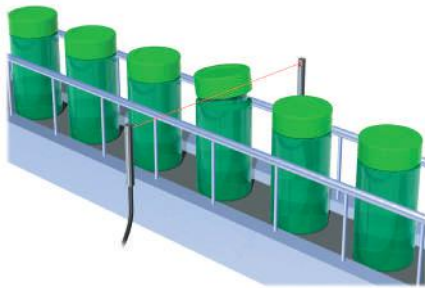

Fiber optic sensor **FTVN5BC** See **P.84**

118

Bottle cap packing detection

Detecting the presence of packing on the back of bottle caps at high speed.

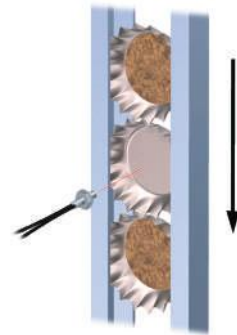

Fiber optic sensor **F70AR FR8EBC** See **P.102**

119

Control of film rolling

Detecting the "sagging" and "rolling diameter" of films for analogue output.

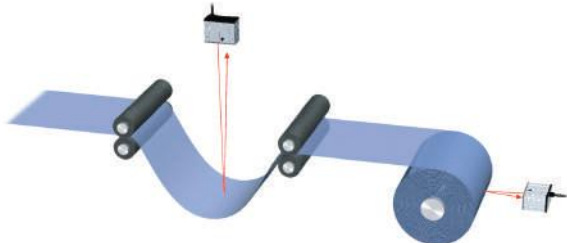

Background suppression photo sensor **DLA-S1000** See **P.268**

120

Distinction of overlap sheets

Dual-output fiber optic sensor used for detecting overlap of sheets.



Fiber optic sensor **F70TR FT5BC** See **P.78**

Sample Applications

Packaging/Food/Drug

121

Detection of teabag strings

Wide area fiber optic cable used for detecting teabag strings on nonwoven fabric conveyor.

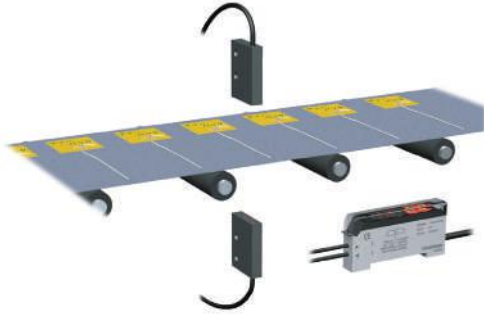

Fiber optic sensor **F70AR FTL716BC** See **P.93**

122

Detection of shampoo bottles

Shampoo bottles positioned before packaging. Light curtain achieving stable detection regardless of bottle shape variation.

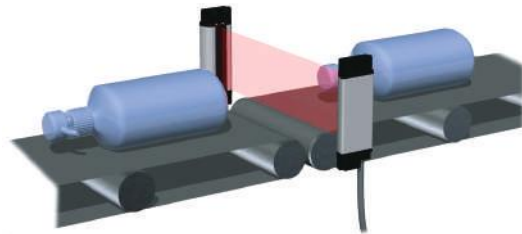

Light curtain sensor **SSC-T800 Series** See **P.460**

123

Detection of rice balls for sushi

Rice balls detected on automatic sushi machine.

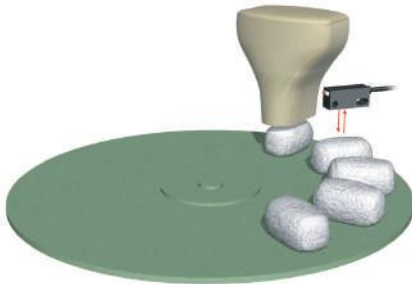

Embedded amplifier photo sensor **UM2-Z3SV** See **P.182**

124

Detection of steamed fish paste on belt conveyor

The limited range reflective sensor detects steamed fish paste without being affected by color, shape or material of the detecting object.

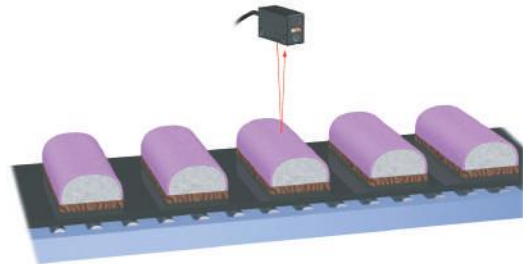

Background suppression photo sensor **DL-S Series** See **P.254**

125

Detection of level of liquid in pipe

Level of transparent or translucent liquid detected. Mounting with zip-tie bands allows flexible mounting.

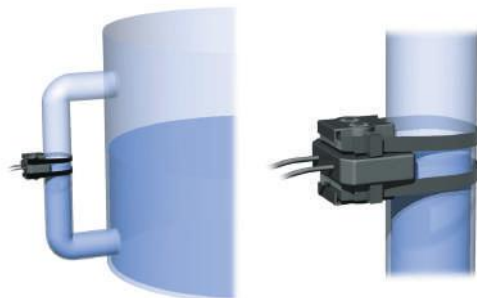

Fiber optic sensor **FU901BC** See **P.141**

126

Detection in chemical atmosphere

Food material in an atmosphere of alcohol can be detected with sensor in PFA case with high environmental resistance.

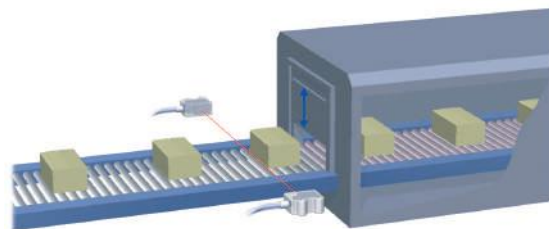

Embedded amplifier photo sensor **PF-T3DS** See **P.314**

Sample Applications

Packaging/Food/Drug

127

Egg package detection

Egg packages detected in packaging process.

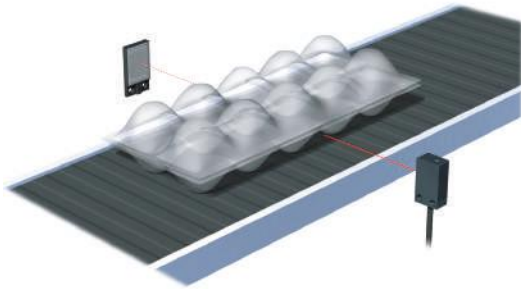

Transparent object detection sensor **GA-MTIR** See **P.370**

128

Detection of slipped labels

Detecting position slipping of labels with a spot optical axis

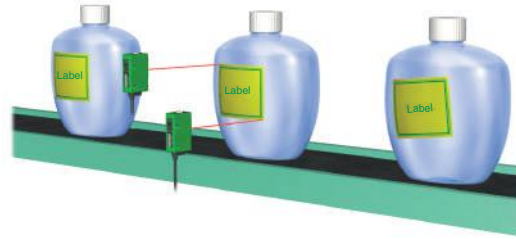

Mark sensor **GR40RN** See **P.290**

129

Content checking

Ultrasonic sensor used for detecting liquid content from outside of bottles through openings.

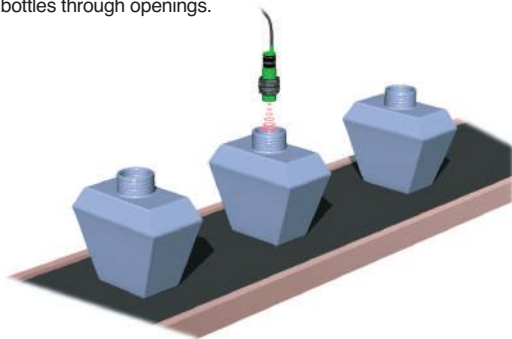

Ultrasonic sensor **US-S25AN** See **P.424**

130

Identification of height of medicines

An ultrasonic sensor identifies the height of colorful objects such as medicines for analogue output.

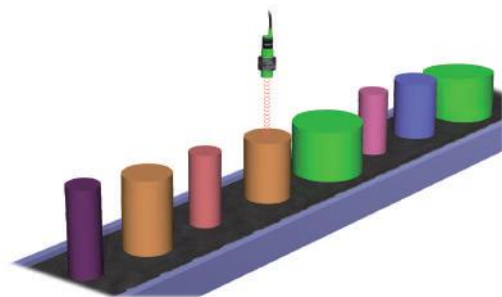

Ultrasonic sensor **US-S25AN** See **P.424**

131

Detection of register marks

The U-shaped sensor detects register marks on wrapping paper with no need to adjust optical axes.

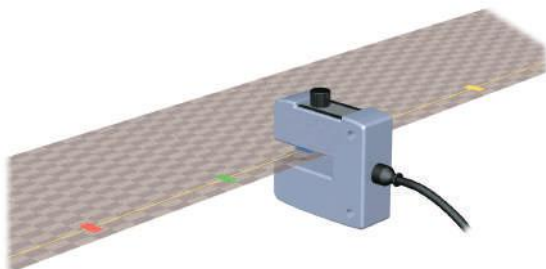

Mark sensor **MU10N** See **P.296**

132

Detection of level of liquid in tank

Level of liquid detected with chemical-resistant PFA fiber optic cable installed inside tank.

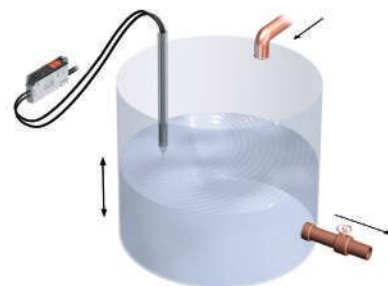

Fiber optic sensor **F70AR FL-7013** See **P.140**

Sample Applications

Packaging/Food/Drug • Safety

133 Transparent film detection

Ultrasonic sensor allowing detection regardless of degree of transparency, color or material.

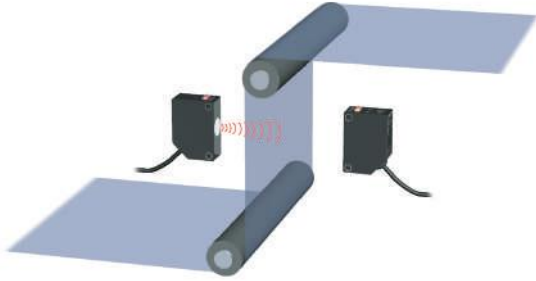

Ultrasonic sensor **US-T50**

See **P.428**

134 Transparent PET bottle detection

Transparent package detection sensor allowing stable detection of uneven surface PET bottles.

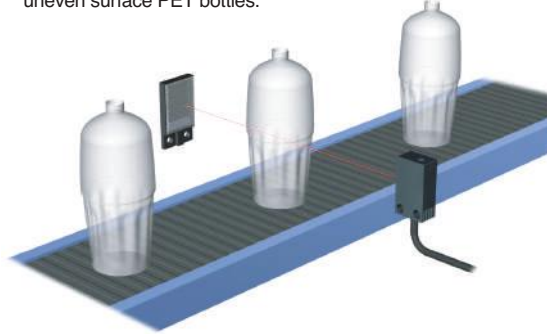

Transparent package detection sensor **GA-MT1R**

See **P.370**

135 Detection of register mark on wrapping paper for Japanese sweets

The U-shaped sensor can be easily installed. Since the lens surface is always cleaned, this is best for mark detection on traditional Japanese paper.

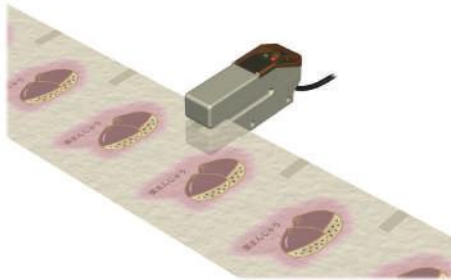

Mark sensor **MC Series**

See **P.294**

136 Label detection

Integrated U-shaped fiber optic cable available for detecting labels for timing operation of labeler.

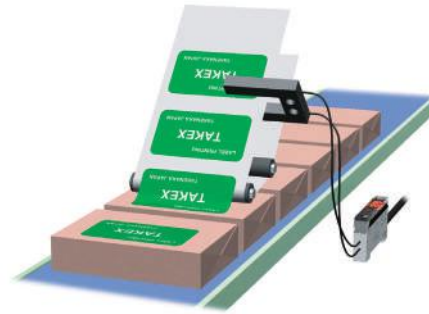

Fiber optic sensor **F70AR FU712BC**

See **P.90**

137 Safety sensor for overhead hazard protection

Light curtain used to alert operators as position of their heads go higher when users go up stairs.



Light curtain sensor **SSR Series**

See **P.492**

138 Detection of ignition

Ultraviolet radiation from flame selectively detected for checking for spontaneous ignition on dust conveyor



UV detection sensor **UV-R200**

Contact Takex for details.

Sample Applications

Safety · Sanitary/Amusement

139

Detection of entering objects into machine

Detecting a human hand coming into a processing machine.

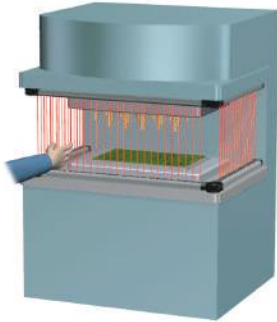

Light curtain sensor **JS2 Series**

See **P.442**

140

Starting switch for game machine

Used as the starting switch for a game machine.

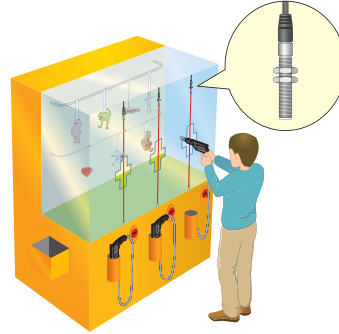

Embedded amplifier photo sensor **UX-T100D**

See **P.178**

141

Sensor for automatic faucet

Hands are detected to turn on water.



Embedded amplifier photo sensor **GN-R40CR**

See **P.188**

142

Sensor for automatic flushing

Users' approaching and leaving detected for flushing.



Embedded amplifier photo sensor **NE-R10-DC**

See **P.220**

143

Sensor for stopping carts

Stationary reflector detected for stopping carts.

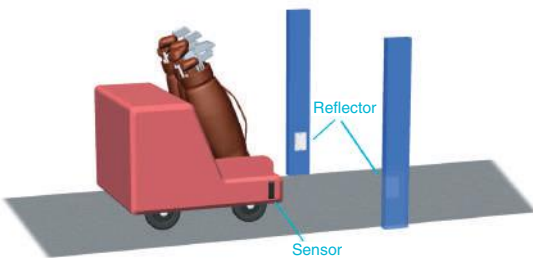

Embedded amplifier photo sensor **GMR2RSN**

See **P.208**

144

Sensor for activating game machine

Hand detected through smoked glass for activating game machine.



Embedded amplifier photo sensor **CX-R01**

See **P.226**

Sample Applications

Sanitary/Amusement · etc.

145 Sensor for hot air drying

Hands putting into dryer are detected for activating sterilization lamp and hot air motor.

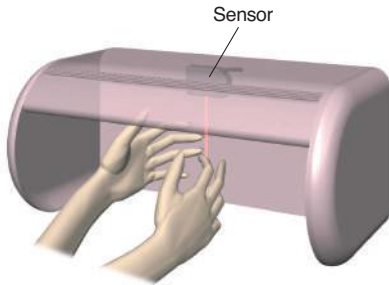

Embedded amplifier photo sensor **GS20SN** See **P.202**

146 Detection of objects in harsh environment

The limited range reflective sensor can detect material even in a harsh environment because it is not affected by dirt on lens or detecting objects.

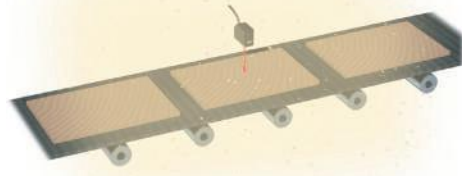

Background suppression photo sensor **DL-S Series** See **P.254**

147 Detection of film in dark room

Sensor for film manufacturing line using infrared light causing less influence on film.

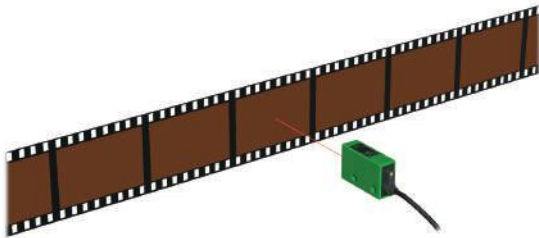

Embedded amplifier photo sensor **GR02-DR** See **P.384**

148 Drum rotation control

Rotational speed of drum for winding or unwinding sheet material controlled.

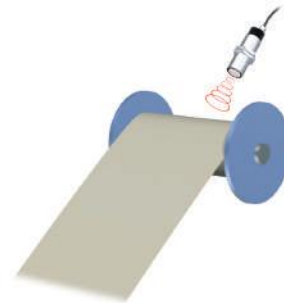

Ultrasonic sensor **USA-S1AN** See **P.416**

149 Detection of still cars in parking lot

Can securely detect presence of a car in a parking space without being affected by color or shape of cars.



Sensor for parking lot **DX-S400** See **P.390**

150 Divergence control

Signal transmitted to divergence point.

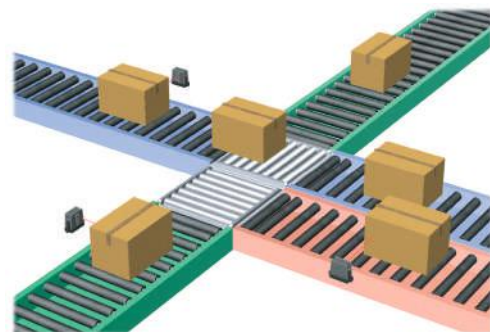

AC/DC power supply photo sensor **J Series** See **P.340**

Sample Applications

etc.

151

Detection of person at entrance

Detection from high ceiling without spoiling the appearance.

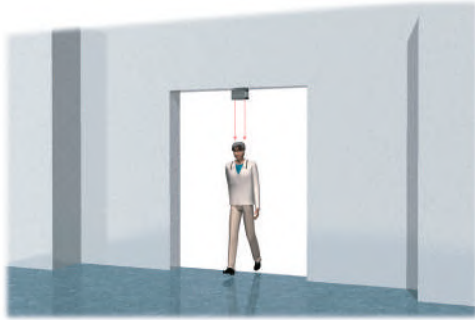

Background suppression photo sensor **DX-7AH** See **P.394**

152

Detection of labels in place

Presence of label in specified position detected.

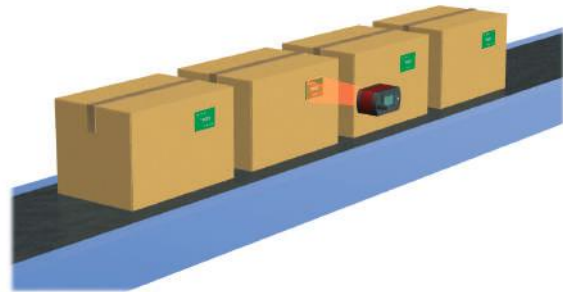

BGS photodiode array sensor **VS-S20R** See **P.362**

153

Detection of remaining person

CD area checked for remaining person at closing time.



Light curtain sensor **SS40 Series** See **P.468**

154

Control of height of industrial radio-controlled helicopter.

Long-distance photo sensor used for detecting height of helicopter from ground.



Vehicle detector in parkinglot **DX-S300W** See **P.390**

155

Guest counting

Various count control available with sensor installed above entrance in combination with counter.

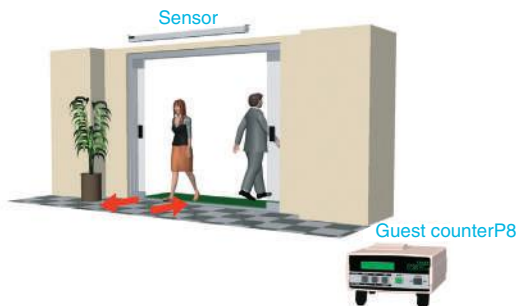

Background suppression wide photo sensor **DW-S** Contact Takex for details.

156

Detection of coated plywood board

Plywood board of various colors detected with back ground suppression photo sensor.

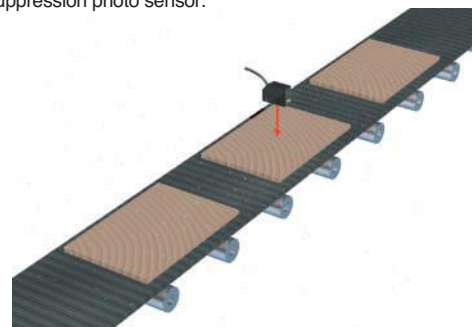

Background suppression photo sensor **DL-S20** See **P.254**